

SET-UP / INSTALLATION INSTRUCTIONS
for MAINTAINED - MANUAL RESET CABLE SWITCHES

04963 - 500 through 04963 - 650	94963 - 500 through 94963 - 650
---------------------------------	---------------------------------

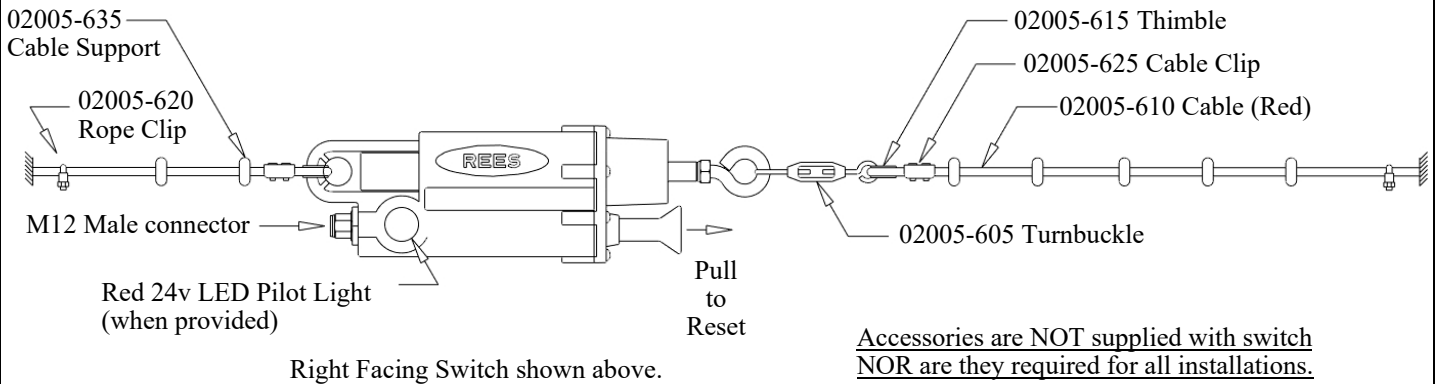

Since every installation is unique and separate, the following instructions can be considered flexible. There are some basic switch setup procedures that must be observed and they are indicated by the symbol (>). The balance of the suggestions and information is subject to change to accommodate those most familiar and responsible for the installation.

INSTALLATION:

1. >Observe all SAFETY REQUIREMENTS and PROCEDURES during installation, set-up and running.
2. >N.E.C. and local wiring codes MUST be followed at all times.
3. The first cable support SHOULD be located 6 to 12 in. (15 to 30 cm) from the switch. (see drawing on other side)
4. The first cable support SHOULD be located so that the cable is aligned with the switch shaft within 5 degrees.
5. It is recommended that the balance of the cable supports be spaced at intervals NOT exceeding 10 feet (~3m). Supports at properly spaced intervals are necessary to ensure that the cable weight will NOT affect switch operation.
6. The maximum recommended cable length is 200 feet (60.69m) in each direction and SHOULD be in as straight of a line as possible.
7. Wiring SHOULD be through the motor control circuit.
(See reference simplified diagram below, and model specific wiring information)

SET-UP and USE:

- > 1. Secure (2 cable clamps per end are recommended) and adjust the SLACK cable length so that there is sufficient "droop" or "swale" in the cable between cable supports.
- > 2. Pull the blue "RESET" knob to set the contacts.
- > 3. Pull the trip cable to test and assure that the switch is functioning properly.
- > 4. After applying control circuit power then repeat step #(s) 2 & 3.
- > 5. NOTE: All cable material will stretch with use and/or temperature variations. If the switch is set-up during extreme conditions a re-adjustment will be necessary to ensure proper switch function.

MAINTENANCE:

1. Regular Preventive Maintenance inspections are recommended.
2. Some conditions to watch for are:
 - a. Proper trip/reset tensions and slack within the trip cable.
 - b. Physical damage to the device.
 - c. Physical damage to the cable.
 - d. Frayed wiring cordset.
 - e. Loose cable connections.
 - f. Any loose components.
 - g. Any worn components.
3. If other assistance is desired please contact the factory.

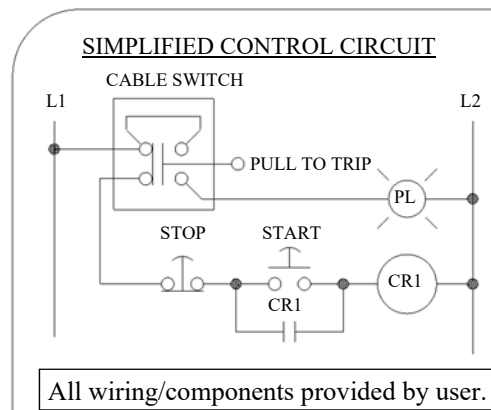

OPERATING SPECIFICATIONS
for MAINTAINED - MANUAL RESET CABLE SWITCHES

04963 - 500 through 04963 - 650 94963 - 500 through 94963 - 650

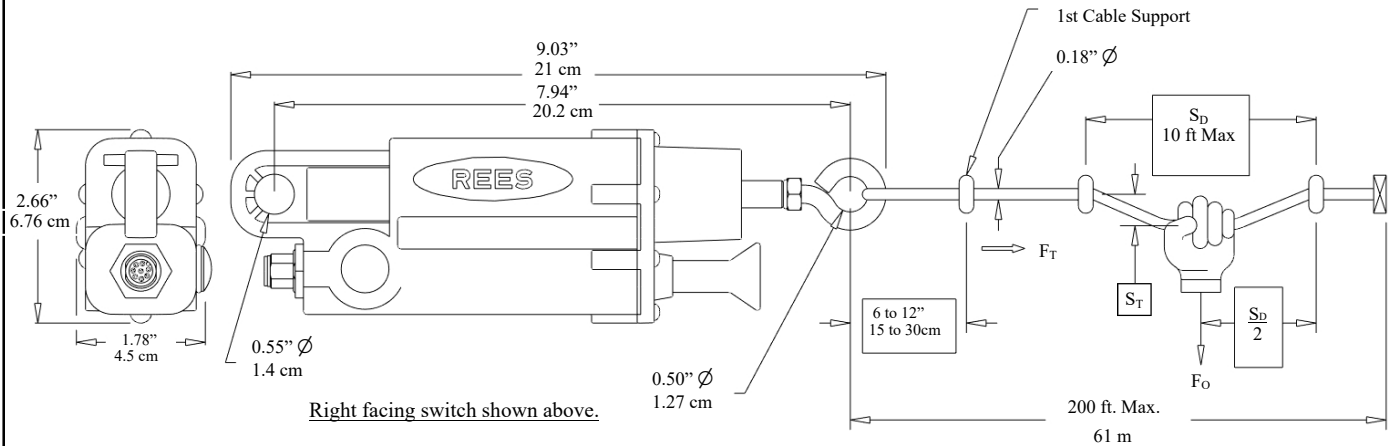

F_T = The value of force, along the cable, which trips the switch.
 F_O = The value of force, applied by the operator perpendicular to the cable, which trips the switch.
 S_D = The distance between the cable supports.
 S_T = The distance the cable is deflected at the time of tripping. * S_T is in addition to any slack "droop" req'd for set-up.

Connector	Pilot Light	Rating	F_T Trip Force	$S_D = 5 \text{ ft. / } 1.5 \text{ m}$		$S_D = 10 \text{ ft. / } 3.0 \text{ m}$	
				F_O	S_T	F_O	S_T
5 Pin M12 Male A-Code	No	60V	15 lb. 6.8 kg	4.5 lb. 2.1 kg	5 in. * 12.7 cm	3.4 lb. 1.6 kg	7 in. * 17.8 cm
	Yes	24V					
8 Pin M12 Male A-Code	No	30V	15 lb. 6.8 kg	4.5 lb. 2.1 kg	5 in. * 12.7 cm	3.4 lb. 1.6 kg	7 in. * 17.8 cm
	Yes	24V					

Warning - Danger
 These products should only be used where point-of-operation guarding devices have been properly installed and maintained so that all appropriate OSHA and ANSI regulations and standards are met. Misapplication of these products on machinery lacking effective point-of-operation safeguards can cause serious injury to the operator of that machinery.

AVERTISSEMENT - DANGER
 Ces produit doivent seulement être utilisés sur des postes à risque correctement sécurisés et entretenus afin d'être conforme aux standards et régulations en vigueur (CSA, CLC). Un mauvais usage de ces produits sur des machines et des postes de travail non sécurisés de manière efficace peut causer des blessures graves au technicien maniant ces machines.

UL listed (File E58589); **NKCR** (E58589) **C-UL-US**;
 Switches comply with UL-508; CSA-C 22.2 No. 14; EN 60947-5-1: 2017;
 04963 versions: Type 4; 94963 versions: Type 4X
 Temperature: Operating = 0°C to +55°C (+32°F to +131°F); Storage = -40°C to +85°C (-40°F to +185°F)
 Mechanical Life Rating = 250,000 operations;
 Operating Position: Can be mounted in any position.

AVAILABLE ACCESSORIES:

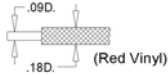
02005-605	02005-610	02005-615	02005-620	02005-625	02005-635
Turnbuckle Tension Adj.	Cable, Steel 	Thimble, Strain Relief	Rope Clip Standard	Cable Clip Optional	Eye Bolt Cable Support
